

ISO Metric fine thread DIN-13

800 800 800 SPN Ms INOX

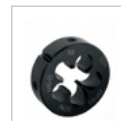
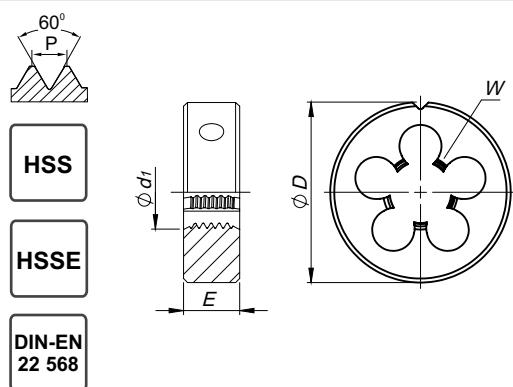

\*SPN - Spiral point

Material groups

P M K	P M K	P M K	P M K	P M K
N S H	N S H	N S H	N S H	N S H

Execution

LH SPN SPN

Quality of material

HSS HSS HSS HSS HSSE

Chamfer

1,75P 1,75P 1,75P 1,25P 2,25P

5

M Ød <sub>1</sub>	P	ØDxE	W		DIN-EN 22 568						
					Norm	6g					
					Tol.	6g	6g	6g	6g	6g	
					INDEX	N1-121001	N1-111001	N1-141001	N1-164001	N2-188001	
M 3,5 x 0,5	0,5	20 x 5	3	3,43	0037	○	○	○	○	○	
M 4 x 0,5	0,5	20 x 5	4	3,92	0041	●	○	●	●	●	
M 4,5 x 0,5	0,5	20 x 5	4	4,43	0046	○	○	○	○	○	
M 5 x 0,5	0,5	20 x 5	4	4,92	0051	●	○	●	●	●	
M 5 x 0,75	0,75	20 x 5	4	4,91	0052	○	○	○	○	○	
M 5,5 x 0,5	0,5	20 x 5	4	5,43	0056	○	○	○	○	○	
M 5,5 x 0,75	0,75	20 x 7	4	5,42	0057	○	○	○	○	○	
M 6 x 0,5	0,5	20 x 5	4	5,92	0061	●	○	●	●	●	
M 6 x 0,75	0,75	20 x 7	4	5,90	0062	●	○	●	●	●	
M 7 x 0,75	0,75	25 x 9	4	6,90	0072	●	○	●	●	●	
M 8 x 0,5	0,5	25 x 9	4	7,92	0081	●	○	●	●	●	
M 8 x 0,75	0,75	25 x 9	4	7,90	0082	●	●	●	●	●	
M 8 x 1	1	25 x 9	4	7,88	0083	●	●	●	●	●	
M 9 x 0,75	0,75	25 x 9	4	8,90	0092	●	●	●	●	●	
M 9 x 1	1	25 x 9	4	8,88	0093	●	●	●	●	●	
M 10 x 0,75	0,75	30 x 11	4	9,90	0102	●	●	●	●	●	
M 10 x 1	1	30 x 11	5	9,88	0103	●	●	●	●	●	
M 10 x 1,25	1,25	30 x 11	4	9,86	0104	●	●	●	●	●	
M 11 x 0,75	0,75	30 x 11	5	10,91	0112	●	○	●	●	●	
M 11 x 1	1	30 x 11	4	10,88	0113	●	○	●	●	●	
M 12 x 1	1	38 x 10	4	11,88	0123	●	●	●	●	●	
M 12 x 1,25	1,25	38 x 10	4	11,86	0124	●	●	●	●	●	
M 12 x 1,5	1,5	38 x 10	4	11,85	0125	●	●	●	●	●	
M 14 x 1	1	38 x 10	5	13,88	0143	●	●	○	●	●	
M 14 x 1,5	1,5	38 x 10	5	13,85	0145	●	●	●	●	●	
M 15 x 1	1	38 x 10	5	14,88	0153	●	○	○	●	●	
M 15 x 1,5	1,5	38 x 10	5	14,85	0155	●	○	○	●	●	
M 16 x 1	1	45 x 14	5	15,88	0163	●	●	○	●	●	
M 16 x 1,5	1,5	45 x 14	5	15,85	0165	●	●	●	●	●	
M 17 x 1	1	45 x 14	5	16,88	0173	●	○	○	●	●	
M 17 x 1,5	1,5	45 x 14	5	16,85	0175	●	○	○	●	●	
M 18 x 1	1	45 x 14	5	17,88	0183	●	●	○	●	●	
M 18 x 1,5	1,5	45 x 14	5	17,85	0185	●	●	●	●	●	
M 18 x 2	2	45 x 14	5	17,82	0186	●	●	●	●	●	
M 20 x 1	1	45 x 14	6	19,80	0203	●	●	●	●	●	
M 20 x 1,5	1,5	45 x 14	6	19,85	0205	●	●	●	●	●	
M 20 x 2	2	45 x 14	6	19,82	0206	●	●	○	●	●	
M 22 x 1	1	55 x 16	6	21,88	0223	●	●	○	●	●	
M 22 x 1,5	1,5	55 x 16	6	21,85	0225	●	●	●	●	●	
M 22 x 2	2	55 x 16	6	21,82	0226	●	●	○	●	●	
M 24 x 1	1	55 x 16	6	23,88	0243	●	●	○	●	●	
M 24 x 1,5	1,5	55 x 16	6	23,85	0245	●	●	●	●	●	

Example of order  
N1-121001-0041  
DIN-EN 22 568 M4x0,5-6g HSS 800

● Available from stock  
○ On request

ISO Metric fine thread DIN-13						800	800	800 SPN	Ms	INOX	
*SPN - Spiral point											
Material groups											
Execution							LH	SPN		SPN	
Quality of material						HSS	HSS	HSS	HSS	HSSE	
Chamfer						1,75P	1,75P	1,75P	1,25P	2,25P	
M Ød <sub>1</sub>	P	ØDxE	W		Norm DIN-EN 22 568						
					Tol.	6g	6g	6g	6g	6g	
						INDEX	N1-121001	N1-111001	N1-141001	N1-164001	N2-188001
M 24 x 2	2	55 x 16	6	23,82	0246	●	●	○	○	○	
M 25 x 1	1	55 x 16	6	24,88	0253	●	○	○	○	○	
M 25 x 1,5	1,5	55 x 16	6	24,85	0255	●	○	○	○	○	
M 25 x 2	2	55 x 16	6	24,82	0256	●	○	○	○	○	
M 26 x 1,5	1,5	55 x 16	6	25,85	0265	●	○	○	○	○	
M 27 x 1	1	65 x 18	6	26,88	0273	●	○	○	○	○	
M 27 x 1,5	1,5	65 x 18	6	26,85	0275	●	○	○	○	○	
M 27 x 2	2	65 x 18	6	26,82	0276	●	○	○	○	○	
M 28 x 1	1	65 x 18	6	27,88	0283	●	○	○	○	○	
M 28 x 1,5	1,5	65 x 18	6	27,85	0285	●	○	○	○	○	
M 28 x 2	2	65 x 18	6	27,82	0286	●	○	○	○	○	
M 30 x 1	1	65 x 18	6	29,88	0303	●	○	○	○	○	
M 30 x 1,5	1,5	65 x 18	6	29,85	0305	●	○	○	○	○	
M 30 x 2	2	65 x 18	6	29,82	0306	●	○	○	○	○	
M 30 x 3	3	65 x 25	6	29,76	0307	●	○	○	○	○	
M 32 x 1,5	1,5	65 x 18	7	31,85	0325	●	○	○	○	○	
M 32 x 2	2	65 x 18	7	31,82	0326	●	○	○	○	○	
M 33 x 1,5	1,5	65 x 18	7	32,85	0335	●	○	○	○	○	
M 33 x 2	2	65 x 18	7	32,82	0336	●	○	○	○	○	
M 33 x 3	3	65 x 25	7	32,76	0337	●	○	○	○	○	
M 35 x 1,5	1,5	65 x 18	7	34,85	0355	●	○	○	○	○	
M 36 x 1,5	1,5	65 x 18	7	35,85	0365	●	○	○	○	○	
M 36 x 2	2	65 x 18	7	35,82	0366	●	○	○	○	○	
M 36 x 3	3	65 x 25	7	35,76	0367	●	○	○	○	○	
M 38 x 1,5	1,5	75 x 20	7	37,85	0385	●	○	○	○	○	
M 39 x 1,5	1,5	75 x 20	7	38,85	0395	●	○	○	○	○	
M 39 x 2	2	75 x 20	7	38,82	0396	●	○	○	○	○	
M 39 x 3	3	75 x 30	7	38,76	0397	●	○	○	○	○	
M 40 x 1,5	1,5	75 x 20	7	39,85	0405	●	○	○	○	○	
M 40 x 2	2	75 x 20	7	39,82	0406	●	○	○	○	○	
M 40 x 3	3	75 x 30	7	39,76	0407	●	○	○	○	○	
M 42 x 1,5	1,5	75 x 20	7	41,85	0425	●	○	○	○	○	
M 42 x 2	2	75 x 20	8	41,82	0426	●	○	○	○	○	
M 42 x 3	3	75 x 30	7	41,76	0427	●	○	○	○	○	
M 45 x 1,5	1,5	90 x 22	7	44,85	0455	●	○	○	○	○	
M 45 x 2	2	90 x 22	7	44,82	0456	●	○	○	○	○	
M 45 x 3	3	90 x 36	7	44,76	0457	●	○	○	○	○	
M 48 x 1,5	1,5	90 x 22	7	47,85	0485	●	○	○	○	○	
M 48 x 2	2	90 x 22	7	47,82	0486	●	○	○	○	○	
M 48 x 3	3	90 x 36	7	47,76	0487	●	○	○	○	○	
M 48 x 4	4	90 x 36	7	47,73	0488	●	○	○	○	○	
M 50 x 1,5	1,5	90 x 22	8	49,85	0505	●	○	○	○	○	



Example of order

 N1-121001-0285  
 DIN-EN 22 568 M28x1,5-6g HSS 800

- Available from stock
- On request